

1	2		3	4	5	6	7	8
REVISIONS								
ISS	ZONE	DESCRIPTION\PER REQUEST\DATE						

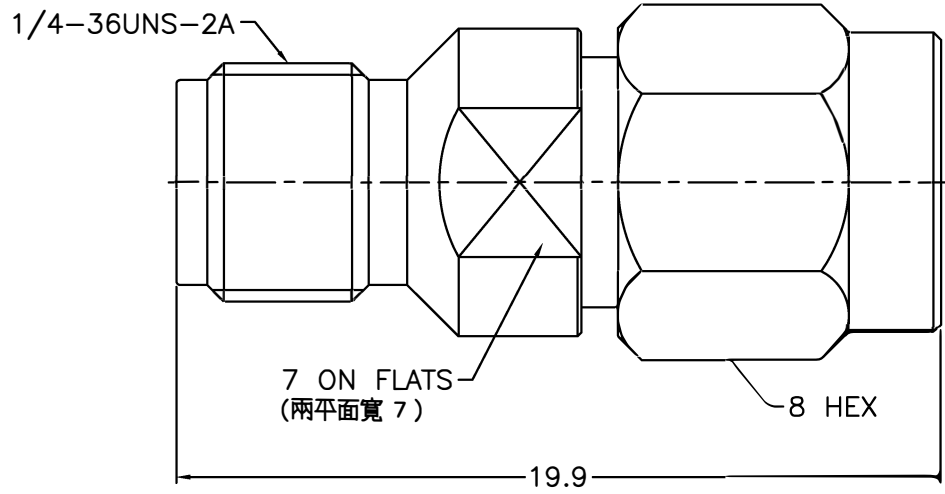

NOTES: FINISH (PLATING THICKNESS IN MICRO-INCHES)
 1. BERYLLIUM COPPER
 2. STAINLESS STEEL
 3. PASSIVATED
 4. GOLD PL. 10 MIN. THICK OVER NICKEL PL. 50 MIN. THICK OVER COPPER PL. 50 MIN. THICK

RoHS COMPLIANT

7	SHELL	NOTE 2	NOTE 3	1	1436-1000-1S	DIMENSIONS ARE IN MILLIMETERS		PART NO.		TITLE 2.92mm PLUG TO JACK ADAPTOR
6	RETAINER RING	SUS 304	NOTE 3	1	1436-1000-4	UNLESS OTHERWISE SPECIFIED TOLERANCES		APPROVED	DATE 07-10-'18	
5	BODY	NOTE 2	NOTE 3	1	292-2071S1-6	0.5-6 = ±0.2 6-30 = ±0.4 30-120 = ±0.6 120-315 = ±1 315-1000 = ±1.6 1000-2000 = ±2.4		CHECKED	DATE 07-10-'18	
4	BODY	NOTE 2	NOTE 3	1	292-5071SA1-5	SCALE 5/1		DRAWN	DATE 07-10-'18	
3	HOUSING	NOTE 2	NOTE 3	1	292-2071S1-4	ISSUE A		DRAWING NO. 292-5071S1-50		DRAWING NO. 292-5071S1-50
2	INSULATOR	ULTEM 1000	NATURAL	1	292-6251S1-3-50U	FILE NO. R:\D\G\DWG\292\5071S1\50		DRAWING NO. 292-5071S1-50		
1	CONTACT PIN	NOTE 1	NOTE 4	1	292-5071S1-1			DATE 07-10-'18		FILE NO. R:\D\G\DWG\292\5071S1\50
NO.	DESCRIPTION	MATERIAL	FINISH	Q'TY	DRAWING NO.	SCALE	5/1	ISSUE	A	

1	2	3	4	5	6	7	8
---	---	---	---	---	---	---	---